

# STAR WARS



**WARNING:**

CHOKING HAZARD—Small parts.  
Not for children under 3 years.

**AGES 4+**  
89000/87931 Asst.

## THE BATTLE OF CRYSTAL CITY™

### AT-AP FEATURES:

Adjust legs to create  
higher “recon” position...

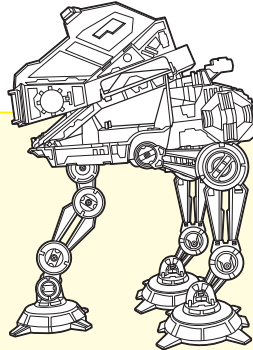
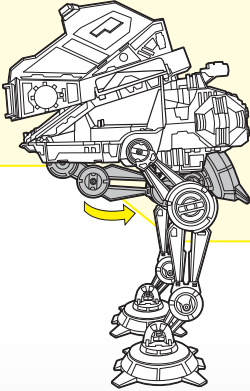

...or lower “scout” position.

Insert missile.

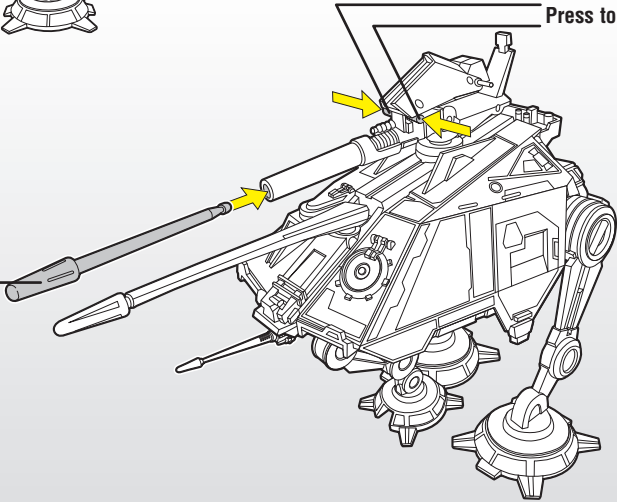

Press to fire.

Apply labels.

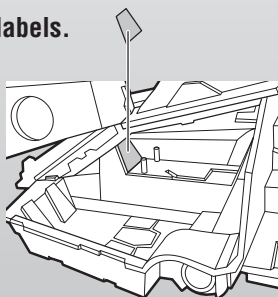
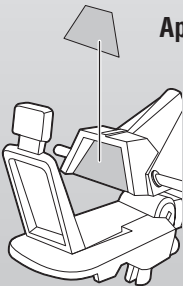

# AAT FEATURES:

Insert missiles into launchers.

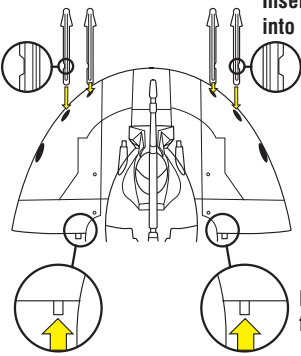

Press buttons to fire missiles.



The 4 pegs on the missile housings allow you to attach figures to the vehicle.

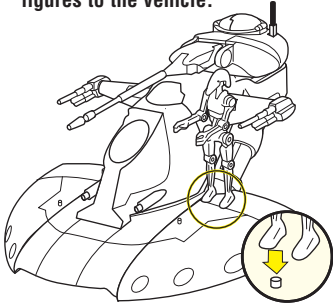

Open hatch and place figure inside. Move lever up to make figure pop out of turret.

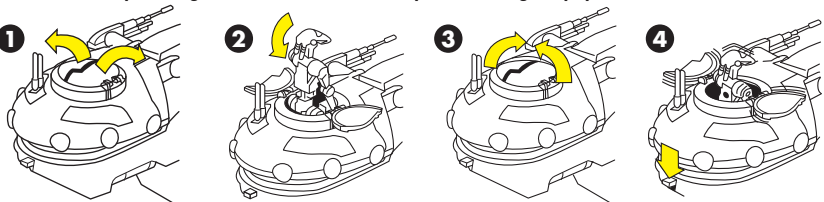

A battle droid fits underneath the removable canopy.

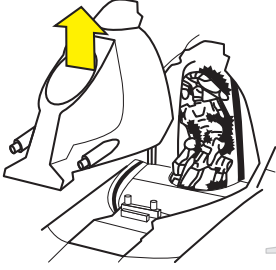

Elevate the primary laser cannon.

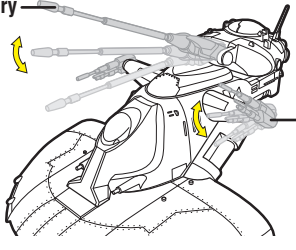

Adjust the secondary laser cannons.

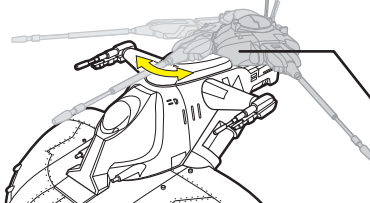

Turret can be rotated 360 degrees.

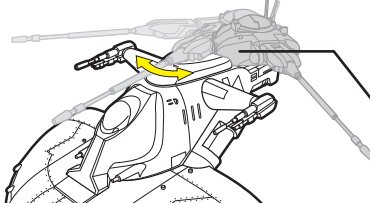

Turn panel to the side showing the undamaged battle droid.

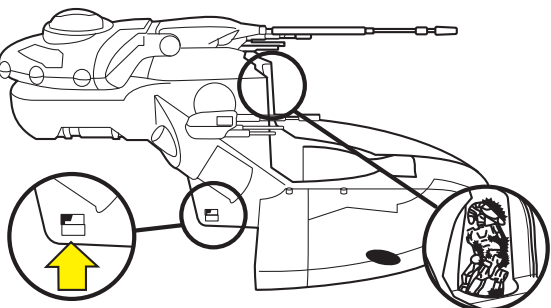
Press button to reveal damaged droid.

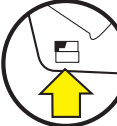

Not suitable for children under 3 years because of small parts — choking hazard.



Product and colors may vary.  
 © 2008 Lucasfilm Ltd. & © or TM where indicated. All rights reserved.  
 ® and/or TM\* & © 2008 Hasbro. All Rights Reserved.  
 TM & © denote U.S. Trademarks.

P/N 6826100000